

ifm electronic



Operating instructions  
Control monitor for  
temperature sensors

**efector600<sup>®</sup>**

**TR2432**

**UK**

04/2011

704774/00

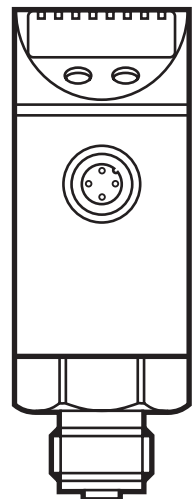

# Contents

1 Preliminary note.....	3
1.1 Symbols used.....	3
2 Safety instructions .....	4
3 Functions and features .....	4
4 Function.....	4
4.1 Communication, parameter setting and evaluation .....	4
4.2 Switching function .....	5
4.3 Analogue function.....	6
5 Installation .....	7
6 Electrical connection.....	8
7 Operating and display elements.....	9
8 Menu.....	10
8.1 Menu structure .....	10
8.2 Explanation of the menu.....	11
9 Parameter setting .....	12
9.1 General parameter setting.....	12
9.2 Configuration of the display (optional).....	14
9.3. Setting of the output signals for OUT1 .....	14
9.3.1 Setting of the output function.....	14
9.3.2 Setting of the switching limits .....	14
9.4 Setting of the output signals for OUT2 .....	14
9.4.1 Setting of the output function.....	14
9.4.2 Scaling of the analogue value .....	14
9.5 User settings (optional) .....	15
9.5.1 Setting the measurement method .....	15
9.5.2 Zero point calibration.....	15
9.5.3 Setting of the delay time for OUT1 .....	15
9.5.4 Setting of the error behaviour of the outputs .....	15
9.5.5 Setting of the switching logic for OUT1 .....	15
9.6 Service functions .....	15
9.6.1 Reading of the min/max values for the system temperature.....	15
9.6.2 Reset of all parameters to factory setting.....	16

10 Operation.....	16
10.1 Reading of the set parameters .....	16
10.2 Fault indication .....	16
11 Scale drawing .....	17
12 Technical data.....	18
12.1 Setting ranges .....	19

# 1 Preliminary note

## 1.1 Symbols used

- ▶ Instruction
- > Reaction, result
- [...] Designation of pushbuttons, buttons or indications
- Cross-reference
-  Important note  
Non-compliance can result in malfunctions or interference.

## 2 Safety instructions

- Please read this document prior to set-up of the unit. Ensure that the product is suitable for your application without any restrictions.
- Improper or non-intended use may lead to malfunctions of the unit or to unwanted effects in your application. That is why installation, electrical connection, set-up, operation and maintenance of the unit must only be carried out by qualified personnel authorised by the machine operator.
- Check the compatibility of the product materials (→ 12 Technical data) with the media to be measured in all applications.

## 3 Functions and features

With temperature sensors connected the unit monitors the system temperature in machinery and plant.

### Connectable temperature sensors:

- Temperature sensors TM, TS or TT.
- Resistance thermometer RTD (Pt 100 or Pt 1000).

The unit automatically detects the connected sensor type and configures itself accordingly. The electrical measuring method (3-wire or 4-wire sensor) is determined via the menu setting (→ 9.5.1).

## 4 Function

### 4.1 Communication, parameter setting and evaluation

- The unit displays the current system temperature.
- It generates 2 output signals according to the parameter setting.

<b>OUT1</b>	Switching signal for system temperature limit value.
<b>OUT2</b>	Analogue signal for system temperature.

- It moreover provides the process data via IO-Link.
- The unit is laid out for fully bidirectional communication. So, the following options are possible:
  - Remote display: Reading and displaying the current system temperature.
  - Remote parameter setting: Reading and changing current parameter settings with the FDT service program ifm Container or via IO-Link.
  - Using the FDT service program ifm Container, the current parameter settings can be stored and transferred to other units of the same type.

The program library of the available DTM objects can be found at [www.ifm.com](http://www.ifm.com)  
 → Service → Download.

Device-specific parameter lists for IO-Link parameter setting are available at:  
[www.ifm.com](http://www.ifm.com) → Select your country → Data sheet direct:

## 4.2 Switching function

OUT1 changes its switching state if it is above or below the set switching limits (SP1, rP1). The following switching functions can be selected:

- Hysteresis function / normally open: [OU1] = [Hno] (→ fig. 1).
- Hysteresis function / normally closed: [OU1] = [Hnc] (→ fig. 1).

First the set point (SP1) is set, then the reset point (rP1) with the requested difference.

- Window function / normally open: [OU1] = [Fno] (→ fig. 2).
- Window function / normally closed: [OU1] = [Fnc] (→ fig. 2).

The width of the window can be set by means of the difference between SP1 and rP1. SP1 = upper value, rP1 = lower value.

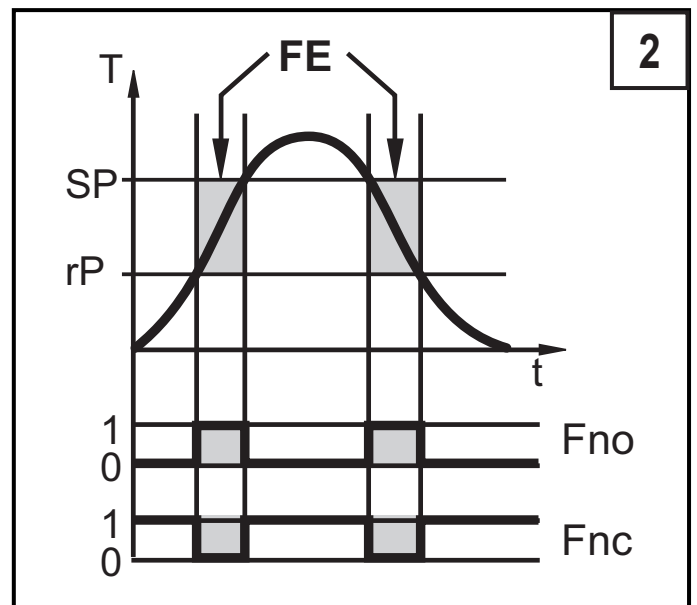
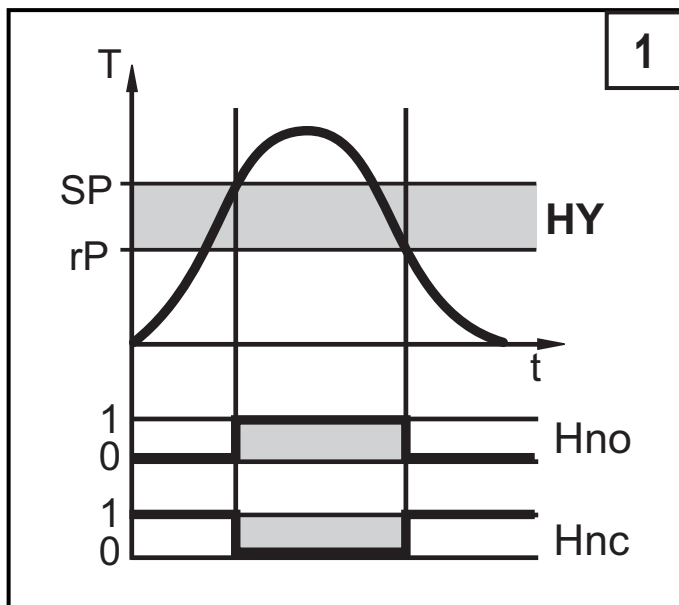

T = system temperature; HY = hysteresis; FE = window

When set to the window function the set and reset points have a fixed hysteresis of 0.25 % of the measuring range. This keeps the switching state of the output stable if the temperature varies slightly.

UK

### 4.3 Analogue function

- [OU2] defines if the set measuring range is provided as a 4...20 mA signal ([OU2] = [I]) or a 0...10 V signal ([OU2] = [U]).
- Analogue start point [ASP] defines at which measured value the output signal is 4 mA / 0 V.
- Analogue end point [AEP] defines at which measured value the output signal is 20 mA / 10 V.

Minimum distance between [ASP] and [AEP] = 5 K.

Current output 4...20 mA

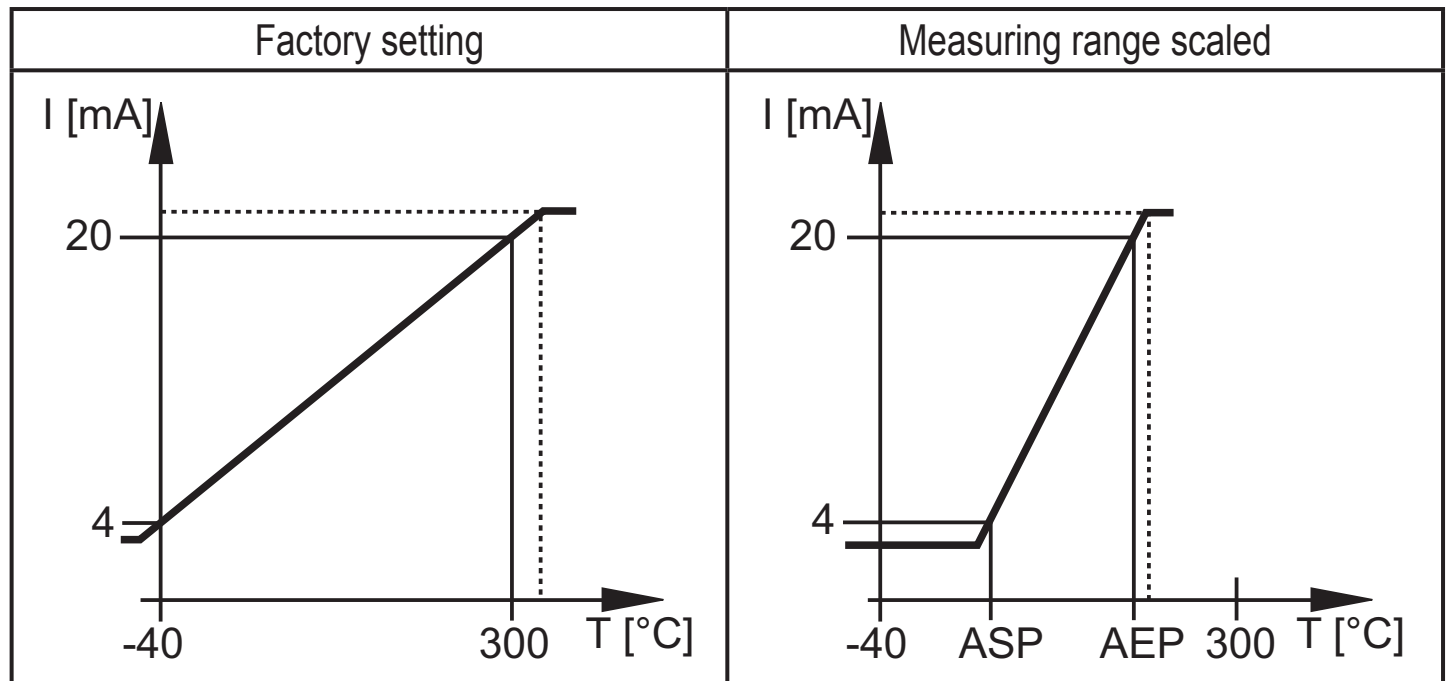

In the set measuring range the output signal is between 4 and 20 mA.

The analogue output also indicates:

- Temperature above the measuring range: Output signal 20...20.5 mA.
- Temperature below the measuring range: Output signal drops to max. 3.8 mA.
- If the detection zone is not reached or is exceeded ( $T < -60^{\circ}\text{C}$  or  $T > +320^{\circ}\text{C}$ ), the output behaves according to the parameter set in FOU2 ( $\rightarrow$  9.5.3).

## Voltage output 0...10 V

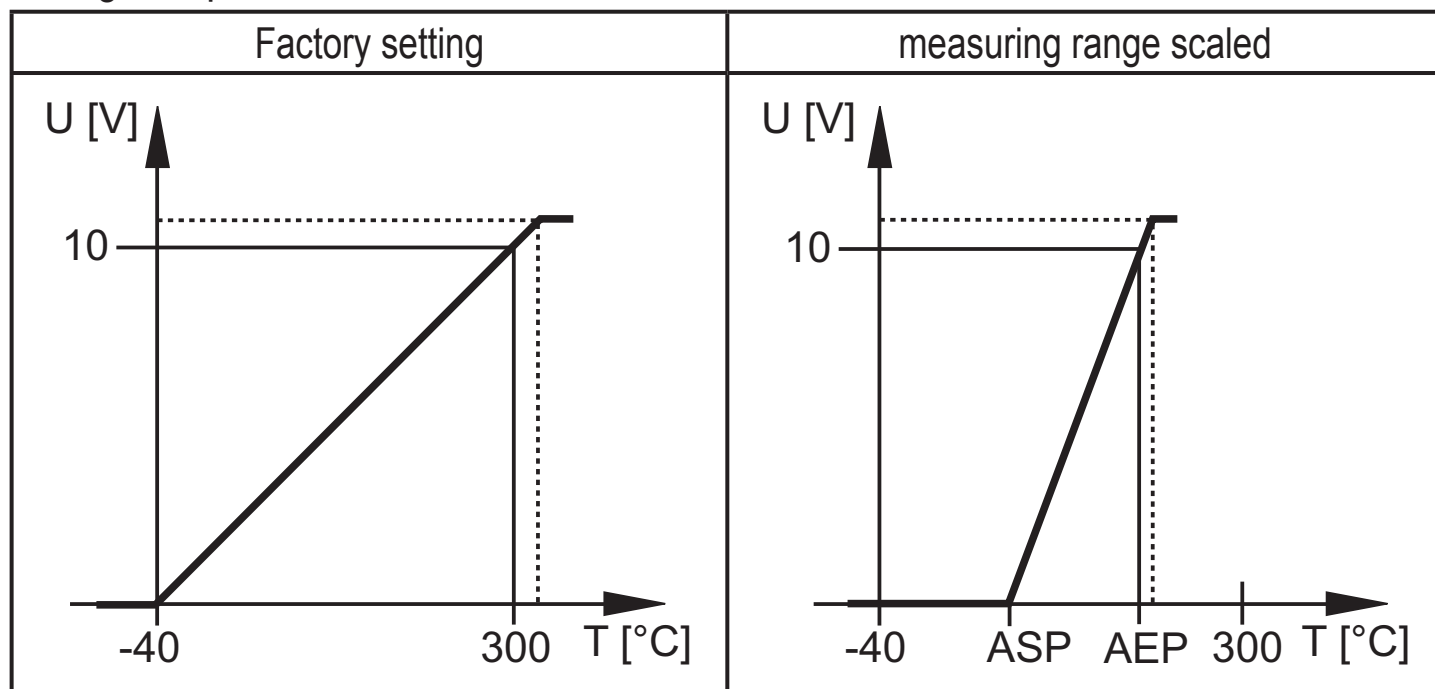

In the set measuring range the output signal is between 0 and 10V.

The analogue output also indicates:

- Temperature above the measuring range: Output signal 10...10.3 V.
- If the detection zone is not reached or is exceeded ( $T < -60^{\circ}\text{C}$  or  $T > +320^{\circ}\text{C}$ ), the output behaves according to the parameter set in FOU2 ( $\rightarrow$  9.5.4).

## 5 Installation

► Connect the unit to a temperature sensor and fix it with the help of mounting accessories.

The following components are available as accessories

	order no.
Mounting set for direct connection of temperature sensors TT	E30017
Mounting clamp $\varnothing$ 34 mm, PBT	E10017
Mounting clamp $\varnothing$ 34 mm, PA	E10193
Mounting device 2 way, POM	E30078
Mounting device 3 way, POM	E30079

## 6 Electrical connection



The unit must be connected by a qualified electrician.

The national and international regulations for the installation of electrical equipment must be adhered to.

Voltage supply to EN 50178, SELV, PELV.

- ▶ Disconnect power.
- ▶ Connect the unit as follows:

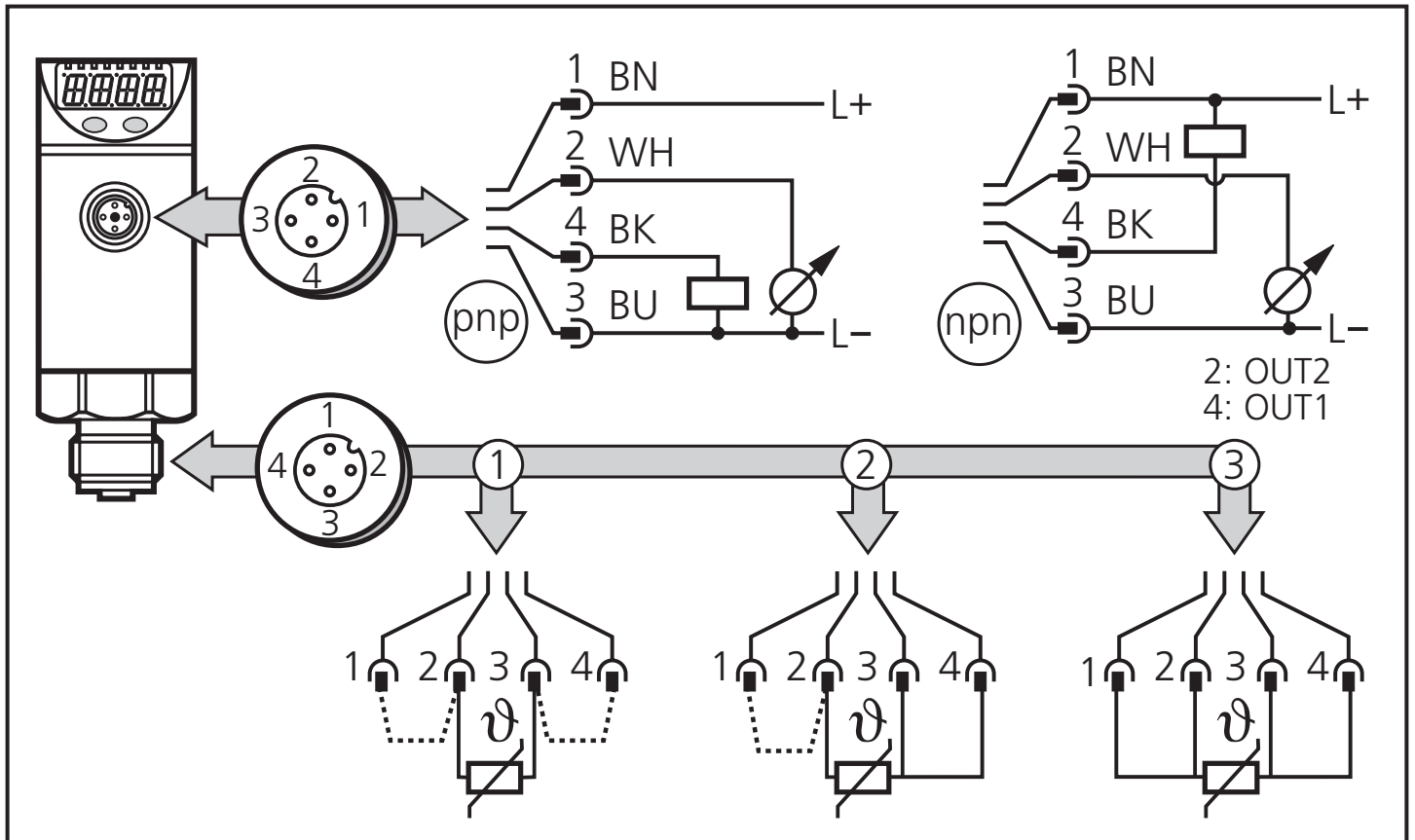

- 1: two-wire sensor
- 2: three-wire sensor
- 3: four-wire sensor

connection for voltage supply and output signals	Pin 1	Ub+
	Pin 3	Ub-
	Pin 4 (OUT1)	<ul style="list-style-type: none"> <li>• Binary switching output temperature monitoring.</li> <li>• Data channel for bidirectional communication.</li> </ul>
	Pin 2 (OUT2)	<ul style="list-style-type: none"> <li>• Analogue signal for temperature.</li> </ul>



connection for temperature sensor	2-wire sensor	Menu setting: Mmod = 4w, links between 1 / 2 and 3 / 4. A wiring fault can be corrected in the menu COF.
	3-wire sensor	Menu setting: Mmod = 3w, link between 1 / 2. The maximum cable resistance of 10 $\Omega$ per core must not be exceeded (this corresponds to a cable length of approx. 80 m for a wire cross-section of 0.14mm <sup>2</sup> ).
	4-wire sensor	Menu setting: Mmod = 4w.

Core colours of ifm sockets:

1 = BN (brown), 2 = WH (white), 3 = BU (blue), 4 = BK (black)

UK

## 7 Operating and display elements

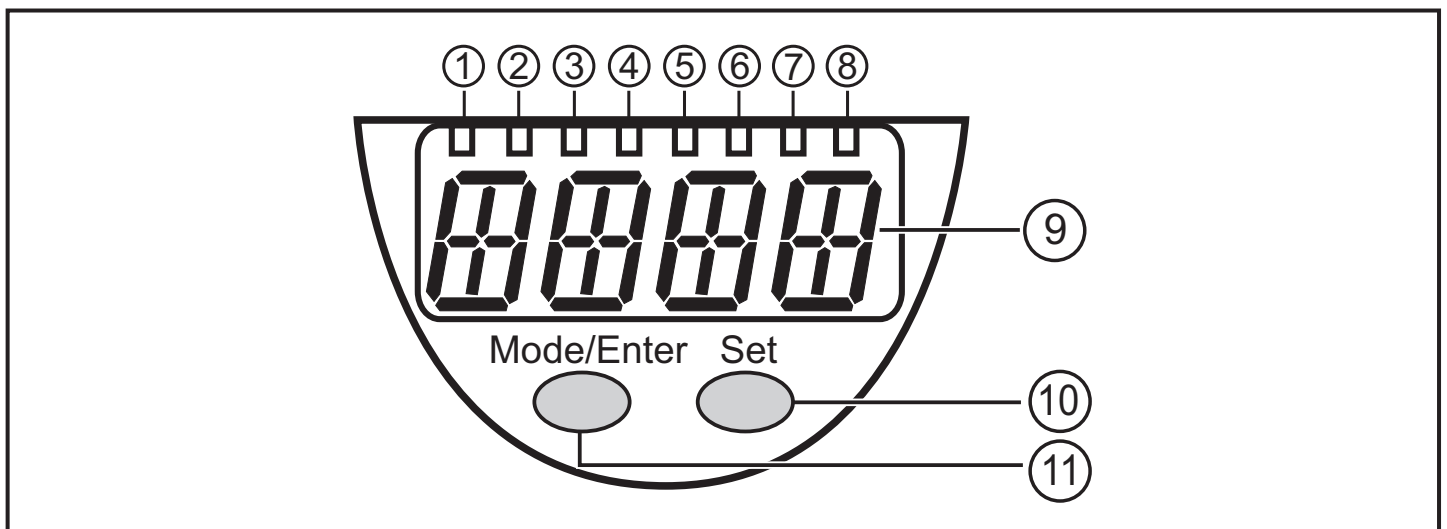

### 1 to 8: Indicator LEDs

- LED 1: Current temperature in °C.
- LED 2: Current temperature in °F.
- LED 8 = Switching status output 1.

### 9: Alphanumeric display, 4 digits

- Display of the current system temperature.
- Indication of the parameters and parameter values.

### 10: Set button

- Setting of the parameter values (scrolling by holding pressed; incrementally by pressing once).

### 11: Mode/Enter button

- Selection of the parameters and acknowledgement of the parameter values.

# 8 Menu

## 8.1 Menu structure

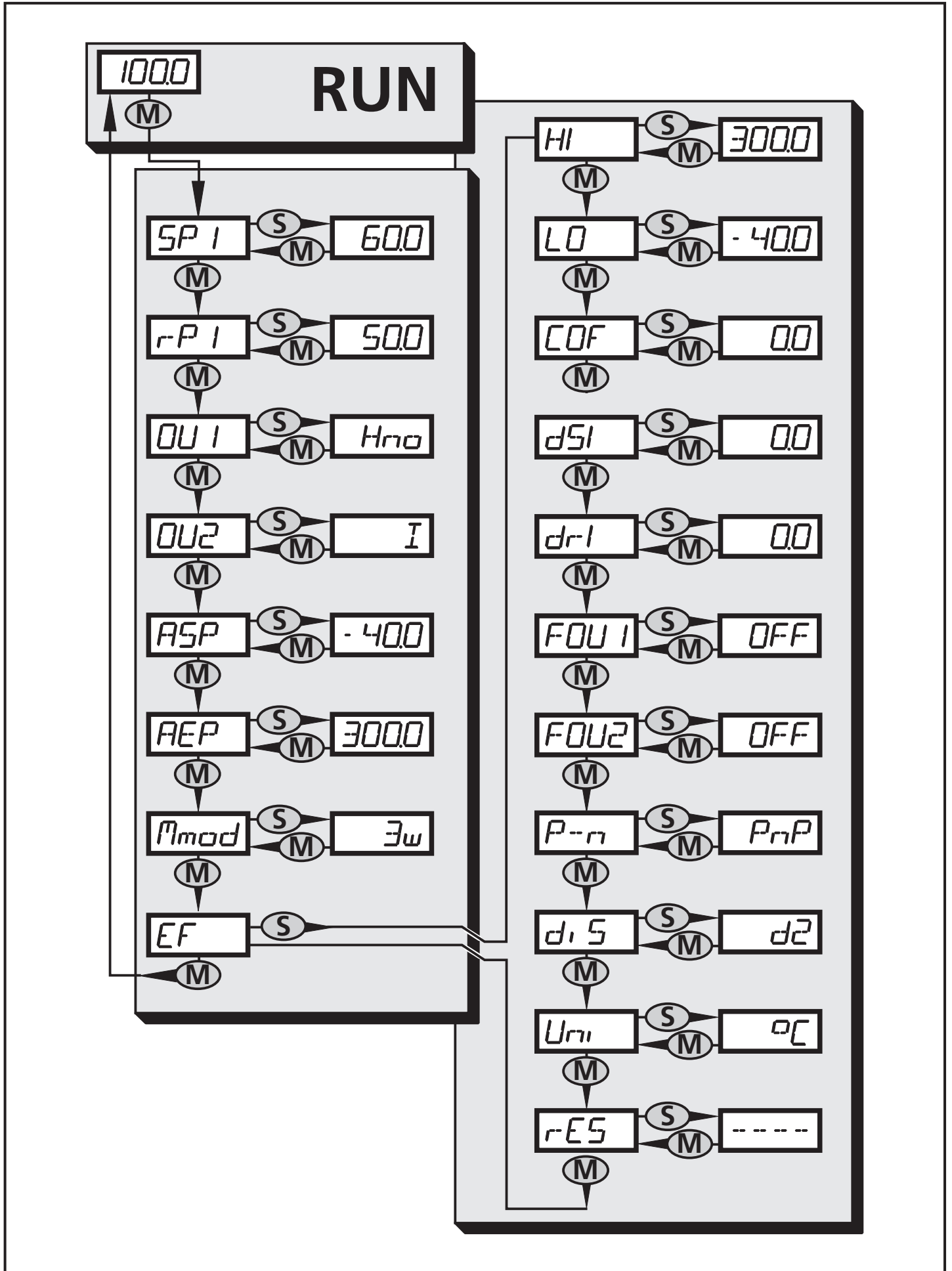

## 8.2 Explanation of the menu

SP1/rP1	Upper / lower limit value for system temperature at which OUT1 switches.
OU1	Output function for OUT1: Switching signal for the temperature limit values: Hysteresis function [H ..] or window function [F ..], either normally open [. no] or normally closed [. nc].
OU2	Output function for OUT2: Analogue signal: 4...20 mA [I] or 0...10 V [U].
ASP	Analogue start value for temperature.
AEP	Analogue end value for temperature.
Mmod	Measurement method (2-wire, 3-wire or 4-wire temperature sensors).
EF	Extended functions / opening of menu level 2.
HI	Maximum value memory for system temperature.
LO	Minimum value memory for system temperature.
COF	Zero-point calibration.
dS1	Switch-on delay for OUT1.
dr1	Reset delay for OUT1.
FOU1	Behaviour of output 1 in case of an internal fault.
FOU2	Behaviour of output 2 in case of an internal fault.
P-n	Switching logic for OUT1: PNP or NPN.
diS	Update rate and orientation of the display.
Uni	Unit of measurement for system temperature.
rES	Restore factory settings.



UK

## 9 Parameter setting

During parameter setting the unit remains in the operating mode. It continues its monitoring function with the existing parameters until the parameter setting has been completed.

### 9.1 General parameter setting

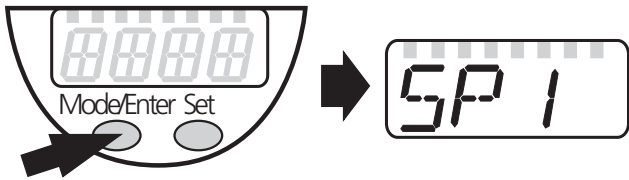
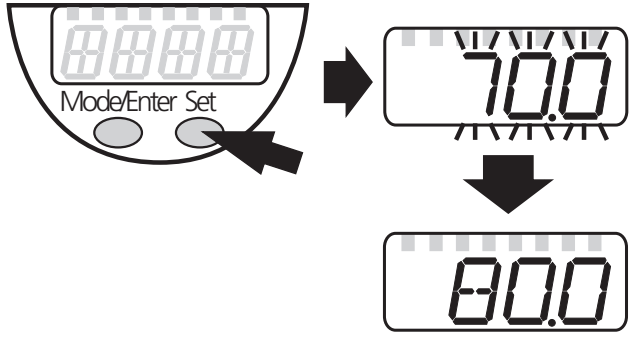
3 steps must be taken for each parameter setting:

<p><b>1</b></p>	<p><b>Selection of the parameter</b></p> <p>▶ Press [Mode/Enter] until the requested parameter is displayed.</p>	
<p><b>2</b></p>	<p><b>Setting of the parameter value</b></p> <p>▶ Press [Set] and keep it pressed.</p> <p>&gt; Current setting value of the parameter flashes for 5 s.</p> <p>&gt; After 5 s: Setting value is changed: incrementally by pressing the button once or continuously by keeping the button pressed.</p>	
<p>Numerical values are incremented continuously. For reducing the value: Let the display move to the maximum setting value. Then the cycle starts again at the minimum setting value.</p>		
<p><b>3</b></p>	<p><b>Acknowledgement of the parameter value</b></p> <p>▶ Press [Mode/Enter] briefly.</p> <p>&gt; The parameter is displayed again. The new setting value is stored.</p>	
<p><b>Setting of other parameters</b></p> <p>▶ Start again with step 1.</p>		
<p><b>Finishing the parameter setting</b></p> <p>▶ Press [Mode/Enter] several times until the current measured value is displayed or wait for 15 s.</p> <p>&gt; The unit returns to the operating mode.</p>		

- If [SLoc] is displayed when attempting a modification of a parameter value, the sensor is locked via software. This locking can only be removed via a parameter setting software.
- In case of parameter setting with the user interface of the ifm Container program, the values can be directly entered in the specified fields.
- For IO-Link parameter setting → device-specific parameter lists at: [www.ifm.com](http://www.ifm.com) → Select your country → Data sheet direct:

- Change from menu level 1 to menu level 2:

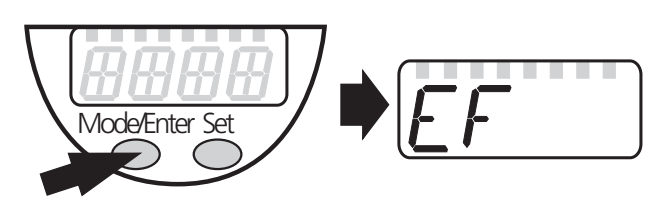
<ul style="list-style-type: none"> <li>▶ Press [Mode/Enter] until [EF] is displayed.</li> </ul> <p>If the submenu is protected with an access code, [Cod1] flashes in the display.</p> <ul style="list-style-type: none"> <li>▶ Press [Set] and keep it pressed until the valid code no. is displayed.</li> <li>▶ Press [Mode/Enter] briefly.</li> </ul> <p>On delivery by ifm electronic: no access restriction.</p>	 <p>The diagram shows a device with a four-digit display. An arrow points to the 'Mode/Enter' button. A second arrow points to a separate display box containing the characters 'EF'.</p>
---	---

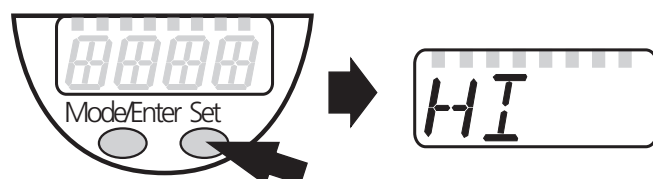
<ul style="list-style-type: none"> <li>▶ Press [Set] briefly.</li> <li>&gt; The first parameter of the sub-menu is displayed (here: [HI]).</li> </ul>	 <p>The diagram shows a device with a four-digit display. An arrow points to the 'Set' button. A second arrow points to a separate display box containing the characters 'HI'.</p>
---	--

UK

With the user interface of the ifm Container program:

- ▶ Activate the [EF] button.

If menu level 2 is protected by an access code, the input field for the code no. is activated.

- ▶ Enter valid code no.

- Locking / unlocking

The unit can be locked electronically to prevent unintentional settings.

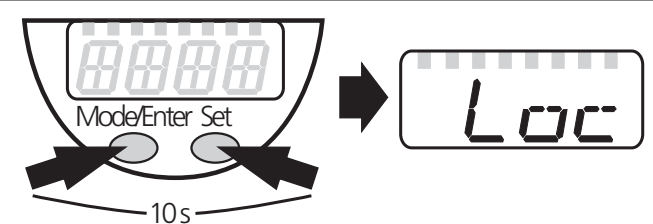
<ul style="list-style-type: none"> <li>▶ Make sure that the unit is in the normal operating mode.</li> <li>▶ Press [Mode/Enter] + [Set] for 10 s.</li> <li>&gt; [Loc] is displayed.</li> </ul>	 <p>The diagram shows a device with a four-digit display. Two arrows point to the 'Mode/Enter' and 'Set' buttons. A bracket below the buttons is labeled '10s'. A second arrow points to a separate display box containing the characters 'Loc'.</p>
--	--

During operation: [Loc] is briefly displayed if you try to change parameter values.

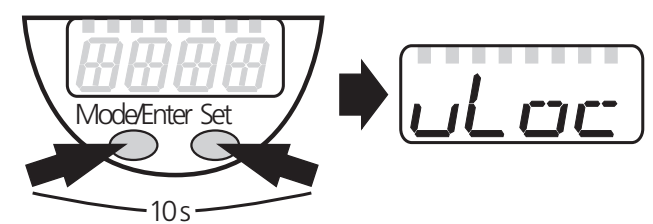
<p>For unlocking:</p> <ul style="list-style-type: none"> <li>▶ Press [Mode/Enter] + [Set] for 10 s.</li> <li>&gt; [uLoc] is displayed.</li> </ul>	 <p>The diagram shows a device with a four-digit display. Two arrows point to the 'Mode/Enter' and 'Set' buttons. A bracket below the buttons is labeled '10s'. A second arrow points to a separate display box containing the characters 'uLoc'.</p>
---	---

On delivery: unlocked.

- Timeout:

If no button is pressed for 15 s during parameter setting, the unit returns to the operating mode with unchanged values.

## 9.2 Configuration of the display (optional)

▶ Select [Uni] and set the unit of measurement: [°C] or [°F].	Uni
▶ Select [diS] and set the update rate and orientation of the display: - [d1]: Update of the measured values every 50 ms. - [d2]: Update of the measured values every 200 ms. - [d3]: Update of the measured values every 600 ms. - [rd1], [rd2], [rd3]: Display as for d1, d2, d3; rotated by 180°. - [OFF]: The display is switched off in the operating mode.	d1 S

## 9.3. Setting of the output signals for OUT1

### 9.3.1 Setting of the output function

▶ Select [OU1] and set the function: - [Hno] = Hysteresis function / normally open. - [Hnc] = Hysteresis function / normally closed. - [Fno] = Window function / normally open. - [Fnc] = Window function / normally closed.	OU 1
--	------

### 9.3.2 Setting of the switching limits

▶ Select [SP1] and set the value at which the output switches.	SP 1
▶ Select [rP1] and set the value at which the output switches off. rP1 is always smaller than SP1. The unit only accepts values which are lower than the value for SP1.	rP 1

## 9.4 Setting of the output signals for OUT2

### 9.4.1 Setting of the output function

▶ Select [OU2] and set the function: - [I] = temperature-proportional current signal (4...20 mA). - [U] = temperature-proportional voltage signal (0...10 V).	OU2
---	-----

### 9.4.2 Scaling of the analogue value

▶ Select [ASP] and set the measured value at which 4 mA / 0 V is provided.	ASP
▶ Select [AEP] and set the measured value at which 20 mA / 10 V is provided. Minimum difference between ASP and AEP = 5 K.	AEP

## 9.5 User settings (optional)

### 9.5.1 Setting the measurement method

<ul style="list-style-type: none"><li>▶ Select [Mmod] and set the value:<ul style="list-style-type: none"><li>- [3w] for 3-wire measurement.</li><li>- [4w] for 2-wire and 4-wire measurement</li></ul></li></ul>	Mmod
---	------

### 9.5.2 Zero point calibration

<ul style="list-style-type: none"><li>▶ Select [COF] and enter value. Setting range:<ul style="list-style-type: none"><li>-10.0...10.0 °C in steps of 0.1 °C.</li><li>-18.0 ...18.0 °F in steps of 0.1° F.</li></ul></li></ul> <p>The internal measured value "0" is shifted by this value.</p>	COF
---	-----

UK

### 9.5.3 Setting of the delay time for OUT1

[dS1] = switch-on delay / [dr1] = switch-off delay. <ul style="list-style-type: none"><li>▶ Select [dS1] or [dr1] and set a value between 0.1 and 50 s (at 0.0 the delay time is not active).</li></ul>	dS1 dr1
---	------------

### 9.5.4 Setting of the error behaviour of the outputs

<ul style="list-style-type: none"><li>▶ Select [FOU1] and set the value:<ul style="list-style-type: none"><li>- [On] = Output 1 switches ON in case of a fault.</li><li>- [OFF] = Output 1 switches OFF in case of a fault.</li></ul></li><li>▶ Select [FOU2] and set the value:<ul style="list-style-type: none"><li>- [On] = The analogue signal goes to the upper limit value (21.0 mA / 10.6 V).</li><li>- [OFF] = The analogue signal goes to the lower limit value (3.5m A / 0 V).</li></ul></li></ul>	FOU1 FOU2
--	--------------

### 9.5.5 Setting of the switching logic for OUT1

<ul style="list-style-type: none"><li>▶ Select [P-n] and set [PnP] or [nPn].</li></ul>	P--n
--	------

## 9.6 Service functions

### 9.6.1 Reading of the min/max values for the system temperature

<ul style="list-style-type: none"><li>▶ Select [HI] or [LO], briefly press [Set]. [HI] = maximum value, [LO] = minimum value.</li></ul> <p>Delete memory:</p> <ul style="list-style-type: none"><li>▶ Select [HI] or [LO].</li><li>▶ Press [Set] and keep it pressed until [----] is displayed.</li><li>▶ Press [Mode/Enter] briefly.</li></ul>	HI LO
---	----------

## 9.6.2 Reset of all parameters to factory setting

- ▶ Select [rES].
  - ▶ Press [Set] and keep it pressed until [----] is displayed.
  - ▶ Press [Mode/Enter] briefly.
- We recommend taking down your own settings in the table before carrying out a reset (→ 13 Factory setting).

r-ES

## 10 Operation

After power on, the unit is in the Run mode (= normal operating mode). It carries out its measurement and evaluation functions and provides output signals according to the set parameters.

Operating indications → Chapter 7 Operating and display elements.

### 10.1 Reading of the set parameters

- ▶ Press [Mode/Enter] until the requested parameter is displayed.
  - ▶ Press [Set] briefly.
- > The unit displays the corresponding parameter value for about 15 s. After another 15 s the unit returns to the Run mode.

### 10.2 Fault indication

[OL]	Temperature too high (measuring range exceeded by more than 3% of the final value of the measuring range).
[UL]	Temperature too low (measuring range below the final value of the measuring range by more than 10%).
[Err]	<ul style="list-style-type: none"><li>• No temperature sensor connected.</li><li>• Fault or short circuit in the temperature sensor, wire break.</li><li>• Detection zone is exceeded (<math>T &lt; -60^{\circ}\text{C}</math> or <math>T &gt; +320^{\circ}\text{C}</math>).</li></ul>
[SC1]	Short circuit in OUT1. The output is switched off as long as the short circuit persists.
[Loc]	Setting pushbuttons of the unit locked, parameter change rejected.
[SLoc]	Unit locked via software, parameter change rejected.
[PARA]	Setting value of a parameter outside the valid range → the unit is not ready for operation. The error may occur with IO-Link parameter setting. If an invalidly set parameter is activated, [PARA] is displayed instead of the parameter value.

The messages Err, PARA and SC1 are shown even if the display is switched off.



Response of the outputs in case of a parameter setting fault [PARA]:

	OUT1	OUT2
Invalid setting [OU1] / [OU2]	OFF	OFF
Invalid setting [FOU1] / [FOU2]	OFF	OFF
Invalid setting [P-n]	OFF	OFF
Invalid setting of other parameters	acc. to setting [FOU1]	acc. to setting [FOU2]

Response of the analogue output in case of a fault [Err], [OL], [UL]:

The set measuring range is not reached.	→ Linear drop of the current signal up to 3.8 mA; the voltage signal remains at 0 V.
The set measuring range is exceeded.	→ Linear increase of the analogue signal to 20.5 mA / 10.3 V.
Detection zone of the sensor is not reached or is exceeded ( $T < -60^{\circ}\text{C}$ or $T > +160^{\circ}\text{C}$ ).	→ Error message [Err]; Analogue signal acc. to setting [FOU2].

UK

## 11 Scale drawing

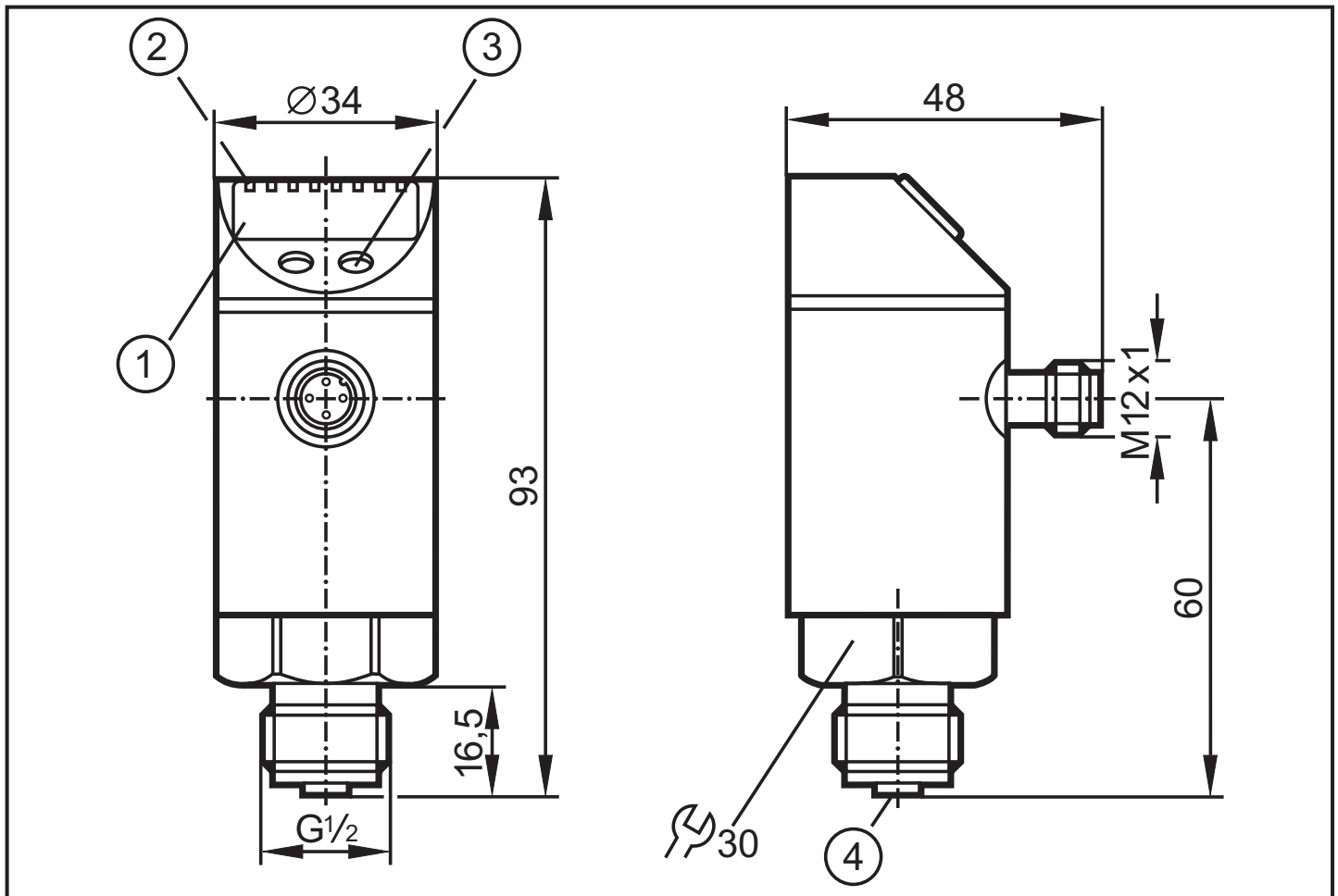

Dimensions in mm

1: Display, 2: LEDs, 3: Programming button, 4: Connector for temperature sensor (M12x1)

## 12 Technical data

Measuring range [°C / °F].....	-40...300 / -40...572
Communication interface .....	IO-Link 1.0
Baud rate [kBAUD] .....	38.4
Operating voltage [V].....	18...32 DC
Current rating [mA] .....	250
Short-circuit protection (pulsed); protected against reverse polarity and overload	
Integrated watchdog	
Voltage drop [V] .....	< 2
Current consumption [mA] .....	< 50
Response time switching output [ms] .....	130
Analogue output .....	4 ... 20 mA / 0 ... 10 V
Max. load current output [Ω] .....	(U <sub>b</sub> - 10 V) x 50
Min. load with voltage output [Ω] .....	2000
Response time analogue output [ms] .....	384
Accuracy	
- switching output [K] .....	± 0.3
- analogue output [K] .....	± 0.3
- display [K].....	± 0.3
Resolution	
- switching output [K] .....	0.1
- analogue output [K] .....	< 0.1
- display [K].....	0.1
Housing materials.....	stainless steel (304S15); EPDM/X (Santoprene); PBT (Pocan); FPM (Viton)
Operating temperature [°C] .....	-25...70
Storage temperature [°C] .....	-40...85
Pressure resistance [bar].....	300
Protection rating .....	IP 67
Protection class .....	III
Shock resistance [g] .....	50 (DIN / IEC 68-2-27, 11 ms)
Vibration resistance [g] .....	20 (DIN / IEC 68-2-6, 10-2000 Hz)
EMC EN 61000-4-2 ESD: .....	4 kV CD / 8 kV AD
EN 61000-4-3 HF radiated: .....	10 V/m
EN 61000-4-4 Burst: .....	2 kV
EN 61000-4-5 Surge: .....	1 kV
EN 61000-4-6 HF conducted: .....	10 V

## 12.1 Setting ranges

TEMP	SP1		rP1		ASP		AEP		$\Delta T$
	min	max	min	max	min	max	min	max	
°C	-39.8	300.0	-40.0	299.8	-40.0	295.0	-35.0	300.0	0.1
°F	-39.6	572.0	-40.0	571.6	-40.0	563.0	-31.0	572.0	0.1

$\Delta T$  = step increment

## 13 Factory setting

	Factory setting	User setting
SP1	60.0	
rP1	50.0	
OU1	Hno	
OU2	I	
ASP	-40.0	
AEP	300.0	
Mmod	4w	
COF	0.0	
dS1	0.0	
dr1	0.0	
dS2	0.0	
dr2	0.0	
FOU1	OFF	
FOU2	OFF	
P-n	PnP	
diS	d2	
Uni	°C	

Further information at [www.ifm.com](http://www.ifm.com)

UK