



IO-Link

# IO-Link modules collect and convert digital signals



IO-Link devices



**Effective connection of binary sensors to IO-Link**

**Adds 20 digital inputs to an IO-Link master**

**For use in industrial applications plus new variant for hygienic areas**

**High protection rating  
IP 68 / 69K**

**Pre-processing of the input signals by digital input filters**



## **Decentralised collection of digital signals via IO-Link**

The new IO-Link input modules for field applications allow easy and economical adding of 20 digital inputs to IO-Link masters.

The activation of digital input filters such as debouncing, stretching or inverting allows easy optimisation of the input signals.

### **Applications**

The module is available in two designs: The orange field module from the coolant series is resistant to oils and coolants and suited for general industrial applications.

The grey module is ideally suited for hygienic and food applications due to the material used for the housing. It has the high protection rating IP 68 / IP 69K.



## Field modules with IO-Link connection

Up to 20 conventional sensors can be connected to these modules. IO-Link transfers the signals to any IO-Link master / PLC via one unscreened M12 cable.

A special feature of the modules is the pre-processing of the input signals via different filters before passing them on to IO-Link.

The following filters are available:

- debouncing (suppress noise signals)
- stretching (longer signals)
- inverting

This allows reliable detection of signals with a minimum length of 1.5 ms.

The decentralised positioning of the module reduces wiring costs and makes complex cabling obsolete. As opposed to bus systems IO-Link does not require any configuration or addressing. This simplifies installation.

Pins 2 and 4 of each M12 socket are configured as binary inputs. That means that dual sensors, normally closed or normally open, can be connected without any problem. The inputs have full overload and short-circuit protection.

## Dimensions

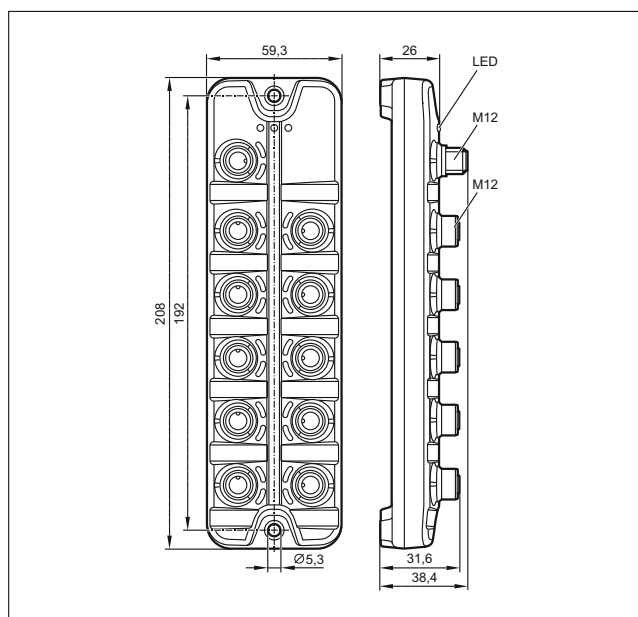

## The products

Design	Description	Order no.
<b>Active IO-Link input module, 10 x 2 inputs</b>		
	IO-Link device V1.1; M12 connector; O-ring; stainless steel thread; IP 68, IP 69K; Food	<b>AL2241</b>
	IO-Link device V1.1; M12 connector; O-ring; stainless steel thread; IP 67; Coolant	<b>AL2341*</b>

\* available from August 2018

## Accessories

Design	Description	Order no.
	IO-Link master with PROFINET interface	<b>AL1100</b>
	USB IO-Link master for parameter setting and analysis of units Supported communication protocols: IO-Link (4.8, 38.4 and 230 Kbits/s)	<b>E30390</b>
	LR DEVICE (supplied on USB flash drive) Software for online and offline parameter setting of IO-Link sensors and actuators	<b>QA0011</b>
	Digital output module Food, IO-Link device V1.1, M12 connector, O-ring, thread: stainless steel, IP 68 / IP 69K	<b>AL2230</b>
	Digital output module Coolant, IO-Link device V1.1, M12 connector, O-ring, thread: nickel-plated brass, IP 67	<b>AL2330</b>